

Traditional 225 RHS



Rain Harvesting System

Choose the Englert® **Traditional 225 RHS** Rain Harvesting System for your residential gardening project. The compact and modular tank design offers a great fit for tight spaces and narrow yards. Easily locate your system below a downspout for quick installation and minimal disturbance to existing landscapes. This user friendly system is ideal for small watering needs and is an economical rainwater system for all budgets.



System Features

- 225 Gal. Capacity with (3) 75 Gal. One-piece Rotationally Molded Tanks
- 3/4" Threaded Hose Bib Connection
- 2" High Flow Top and Bottom Ports
- Integral Downspout Filter Pad
- Child Safe and Mosquito Proof
- Constructed of UV-resistant Black Polyethylene
- 1 HP Automatic Pump with Run-dry Protection and Connection Kit
- Optional Pump Enclosure
- Sign and Label Kit

Advantages

- Easily installed as a complete kit with all installation accessories
- Expandable design for unlimited storage
- Square design for tight spaces
- Single source warranty
- Low cost complete system

*WARRANTY: Englert offers a One (1) Year Limited Warranty for Traditional Series Tanks which provides for the repair or replacement of any defect in a Traditional Series tank caused by our manufacturing process. For all other system components, Englert offers a standard One (1) Year Limited Warranty which provides for the supply of replacements for any such products that are determined to be defective. The Limited Warranty applies only to products and systems that have been designed and installed in accordance with Englert's design and installation instructions. Certain conditions and exclusions apply.

NOTE: Graphic representations are for illustrative purposes only. Data subject to alterations.
© 2009 All rights reserved. Printed in USA

Traditional 225 RHS Rain Harvesting System



Technical Data

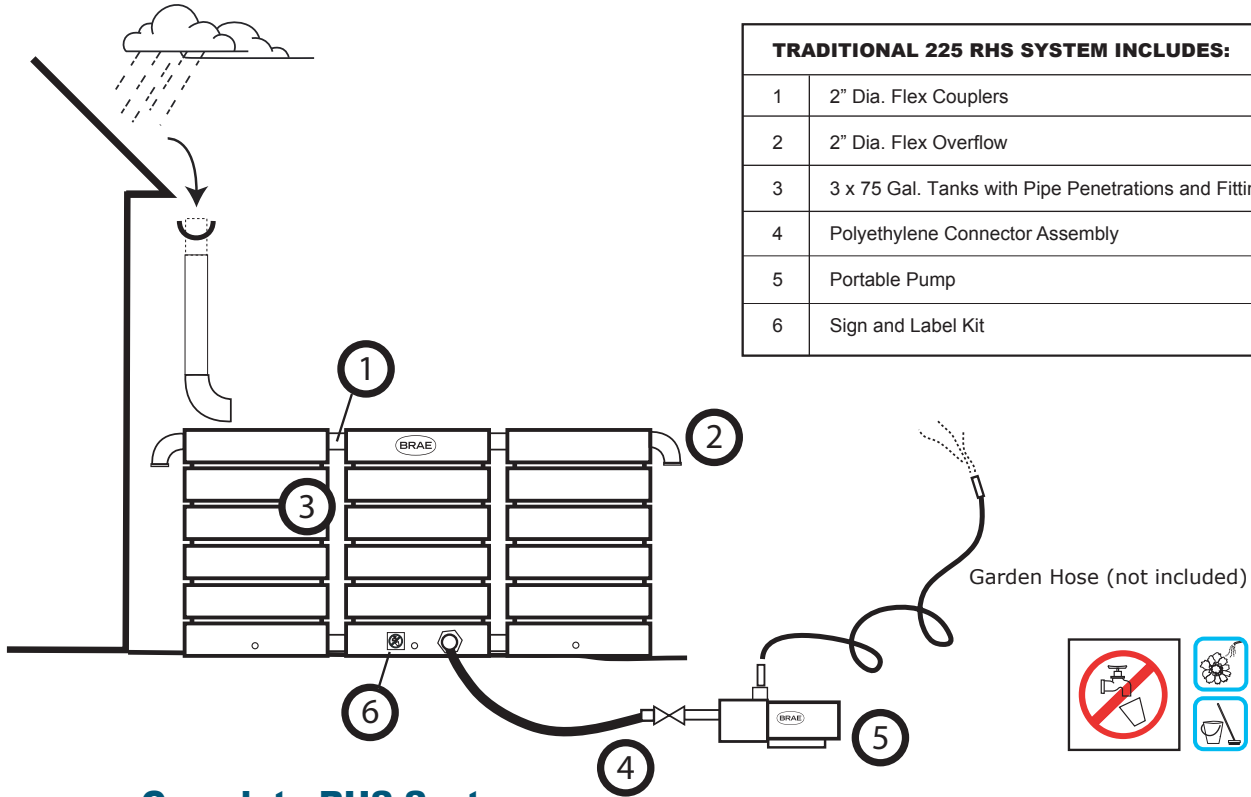

TRADITIONAL 225 RHS SYSTEM INCLUDES:	
1	2" Dia. Flex Couplers
2	2" Dia. Flex Overflow
3	3 x 75 Gal. Tanks with Pipe Penetrations and Fittings
4	Polyethylene Connector Assembly
5	Portable Pump
6	Sign and Label Kit

Complete RHS System

PART NO.	DESCRIPTION	COLOR
089B001	Englert Traditional 225 RHS System	BLACK

OET22530015 Additional 75 Gal. Tank

Tank Dimensions

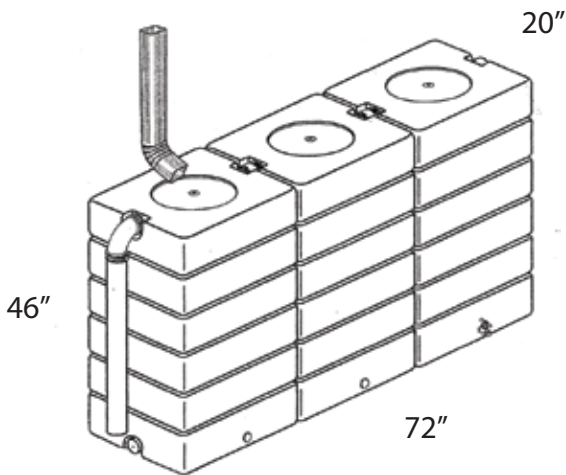

(1) 75 Gal. Tank: **Depth** **Length** **Height**
 20 In. 24 In. 46 In.

Pump Curve

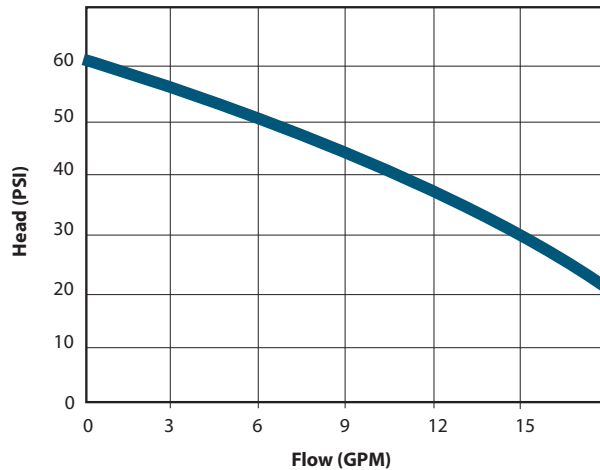

Pump Specs

Pwr. 1 x 110 VAC
Wt. 29 Lbs.
Flow Up to 20 GPM
Lift 25 Ft.
FLA 10.4



Call: 345 949-1699
Email: watmet@candw.ky
watlersmetalproducts.ky