



Choose the Englert® **CLASSIC 400 RHS** Rainwater Harvesting System for your home. The slim tank design offers a great fit for tight spaces and narrow yards. Easily locate your system below a down-spout for quick installation and minimal disturbance to existing landscapes. This user friendly system is ideal for small to mid-range watering needs and is extremely cost effective.

System Features

- 400 Gal. One-piece Rotationally Molded Polyethylene Tank
- Tank Available in 3 Popular Colors (Desert Tan, Forest Green, Black)
- 3 Year Warranty*
- Screened 4" Overflow
- Leaf Eater® Downspout Filter
- Rain Harvesting First Flush Diverter Kit
- 3" Calming Inlet
- 1 HP Automatic Pump with Run-dry Protection and Connection Kit
- Sign and Label Kit



Advantages

- ✓ Easily installed as a complete kit with all installation accessories
- ✓ Single source warranty
- ✓ Slim design for tight spaces
- ✓ Low cost complete system

**WARRANTY: Englert offers a Three (3) Year Limited Warranty for Classic Series Tanks which provides for the repair or replacement of any defect in a Classic Series tank caused by our manufacturing process. For all other system components, Englert offers a standard One (1) Year Limited Warranty which provides for the supply of replacements for any such products that are determined to be defective. The Limited Warranty applies only to products and systems that have been designed and installed in accordance with Englert's design and installation instructions. Certain conditions and exclusions may apply.*

Technical Data

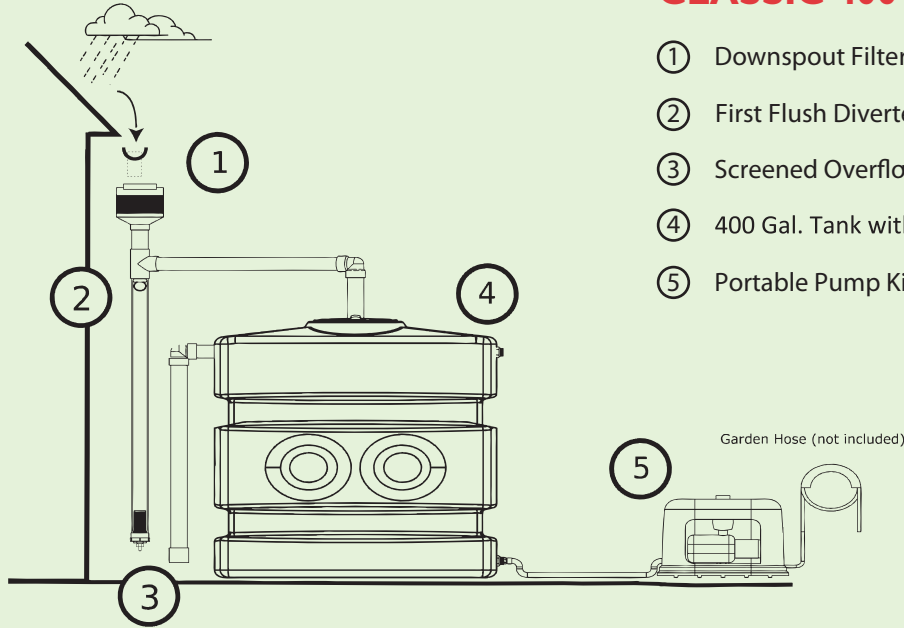

CLASSIC 400 RHS SYSTEM INCLUDES:

- ① Downspout Filter
- ② First Flush Diverter Kit with Piping
- ③ Screened Overflow, 4" Dia.
- ④ 400 Gal. Tank with Pipe Penetrations and Fittings
- ⑤ Portable Pump Kit



Complete RHS Systems

PART NO.	DESCRIPTION	COLOR
089B002B	ENGLERT CLASSIC 400 RHS	BLACK
089B002T	ENGLERT CLASSIC 400 RHS	DESERT TAN
089B002G	ENGLERT CLASSIC 400 RHS	FOREST GREEN

Tank Dimension

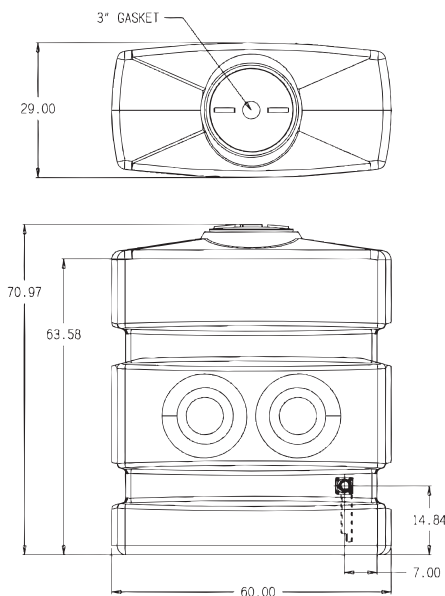

Pump Curve

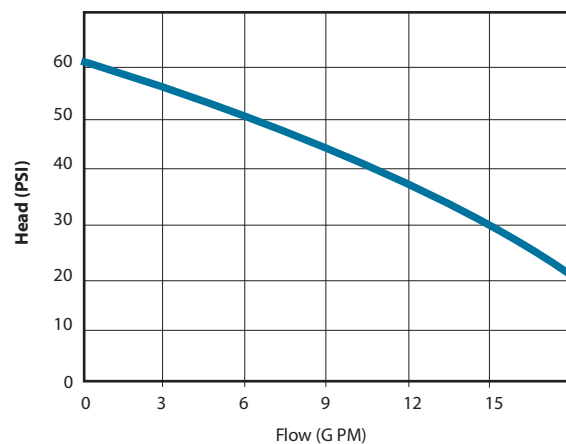

Pump Specs

- Power 1 x 110 VAC
- Weight 29 Lbs.
- Flow Up to 20 GPM
- Lift 25 Ft.
- FLA 10.4



Call: 345 949-1699
Email: watmet@candw.ky
watlersmetalproducts.ky